

4 november 2021

Dit document maakt gebruik van hyperlinks, dus je kunt klikken op de blokken met *benadrukte tekst* om naar de definitie van dat blok te gaan.

1 Software ontwerp

Overzicht

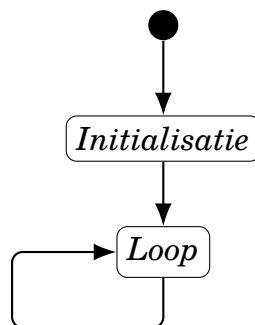

Initialisatie

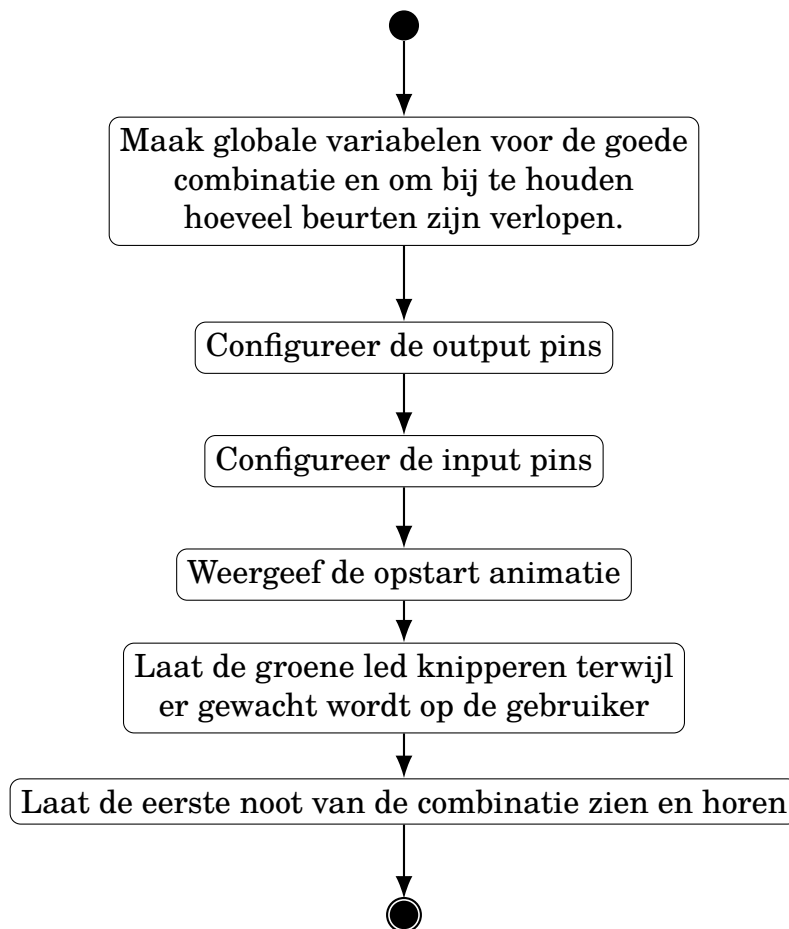

Loop

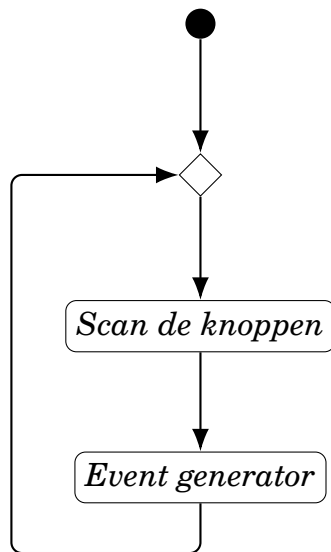

Knoppen scan

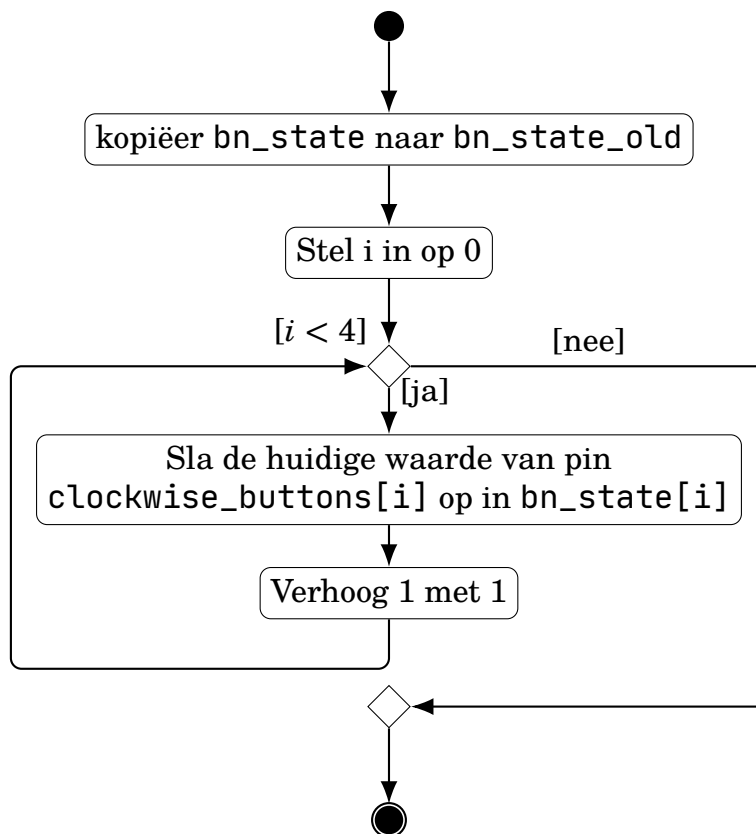

Event generator

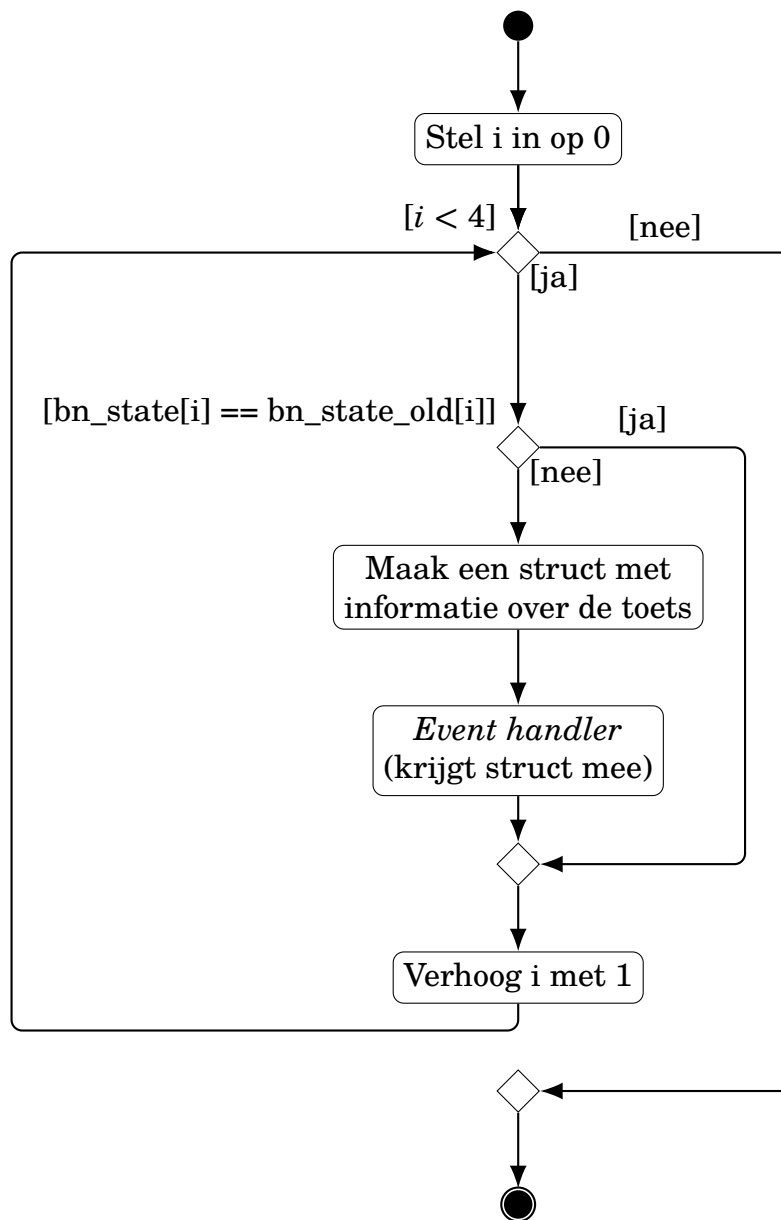

Event handler

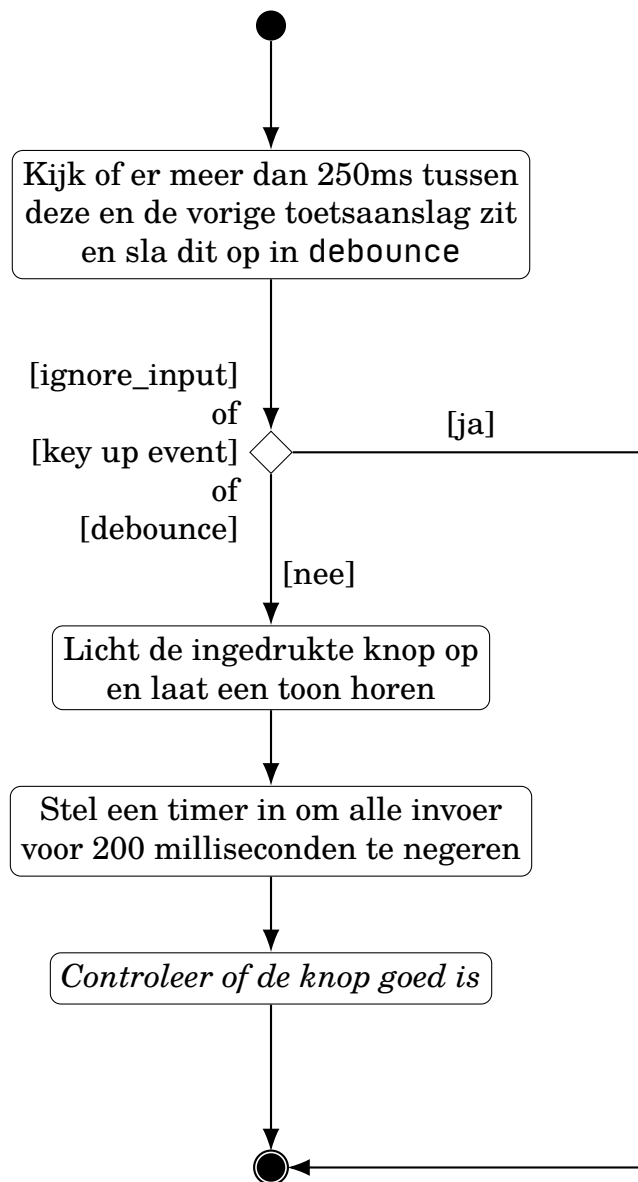

Controleer of de knop goed is

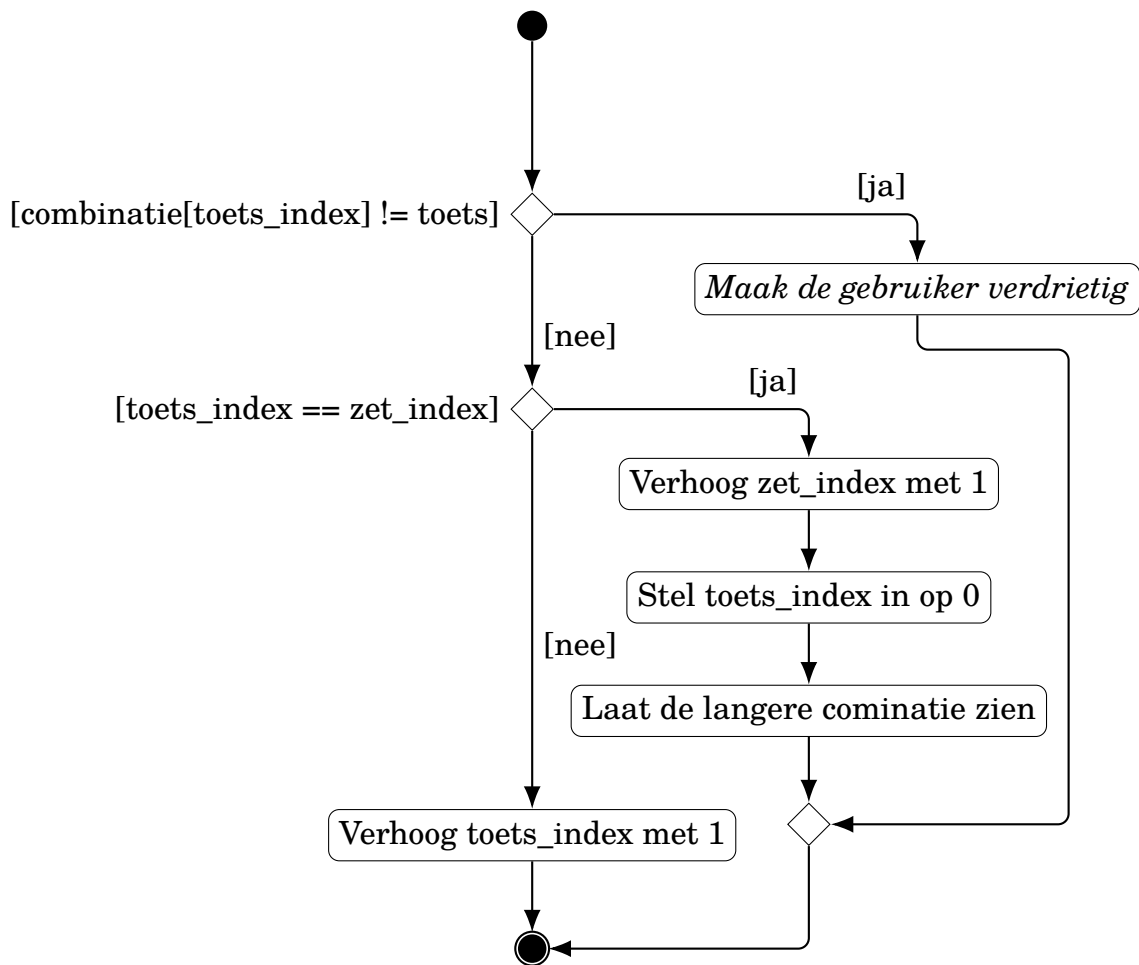

Verkeerde knop routine

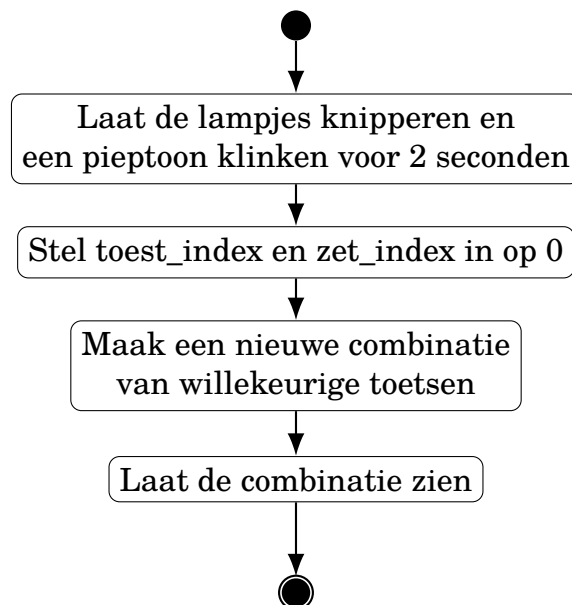

2 Hardware

2.1 Schema

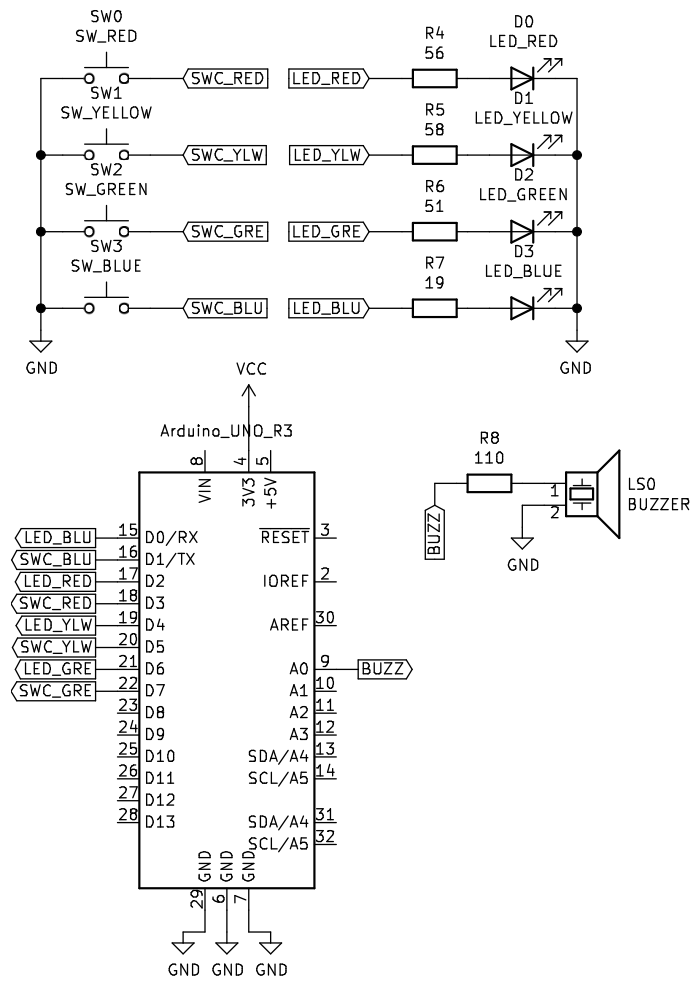

2.2 PCB

